

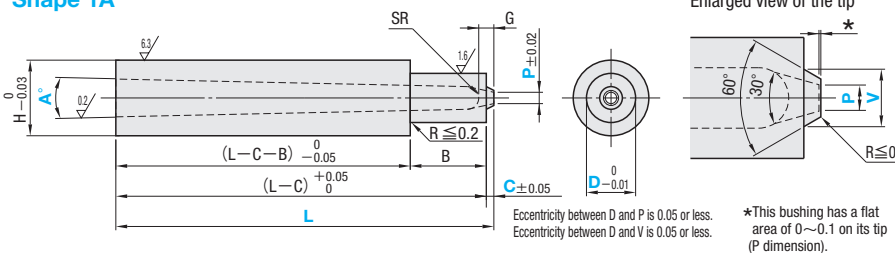







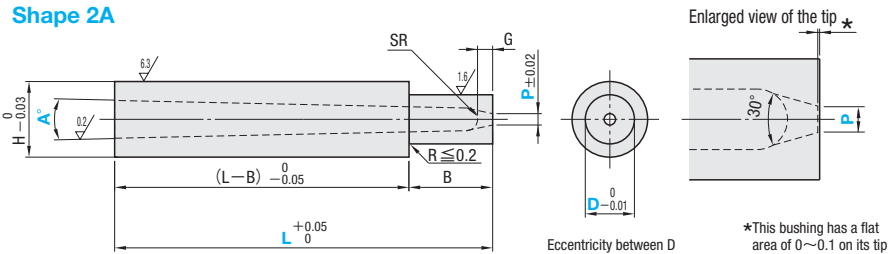

Ⓜ Non JIS material definition is listed on P.1351 - 1352

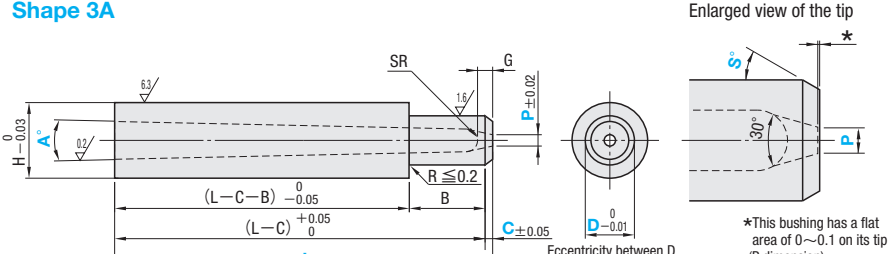
	<p>RoHS</p> <p>Shape 1A</p>  <p>Enlarged view of the tip</p> <p>*This bushing has a flat area of 0~0.1 on its tip (P dimension).</p>
	<p>RoHS</p> <p>Shape 2A</p>  <p>Enlarged view of the tip</p> <p>*This bushing has a flat area of 0~0.1 on its tip (P dimension).</p>
	<p>RoHS</p> <p>Shape 3A</p>  <p>Enlarged view of the tip</p> <p>*This bushing has a flat area of 0~0.1 on its tip (P dimension).</p>
	<p>RoHS</p> <p>Shape 4A</p>  <p>Enlarged view of the tip</p> <p>*This bushing has a flat area of 0~0.1 on its tip (P dimension).</p> <p>Ⓜ $R \geq \sqrt{(P/2)^2 + C^2}$ Ⓜ $V = 2 \times \sqrt{R^2 - (\sqrt{R^2 - (P/2)^2} - C)^2}$</p>
	<p>RoHS</p> <p>Shape 5A</p>  <p>Enlarged view of the tip</p> <p>*This bushing has a flat area of 0~0.1 on its tip (P dimension).</p>

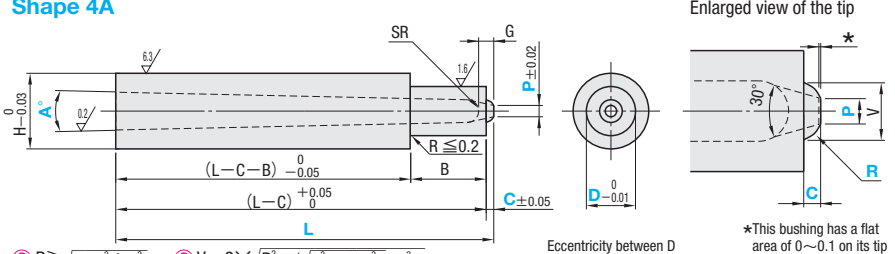
• Calculation for the inlet diameter * α * $\alpha = 2SR + 2(L - G - SR)\tan \frac{A^\circ}{2}$

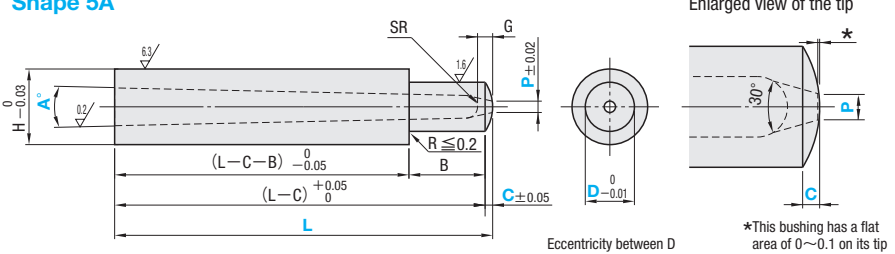
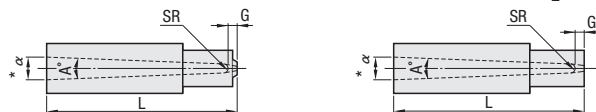

Ⓜ The dimension acquired using the above calculation is the theoretical (reference) value.

Part Number	Type	M	H
PGEBA	Standard	Nickel alloy	(Inside) 55~60HRC depth: 0.5 (Outside) 40~45HRC
PGKBA	High hardness	Nickel alloy	58~62HRC (The inner and outer surface have the same hardness)

Please use the D dimension designation type PGED and PGKD (P.859), if D dimension is designated.

H	G	B	SR	Part Number		L 0.01mm increments	P	A°	None for 2A	Shape 1A only	Shape 3A only	Shape 4A only
				Type	Shape				C 0.1mm increments	V 0.1mm increments	S 1° increments	R 0.1mm increments
3	0.7	3	0.60	PGEBA (Standard type)	1A	2	6.00~20.00	0.3 0.4	1	0.2~0.4	1.3~1.9	0.4~0.8
4	1.0	4	0.75		2.5	8.00~25.00	0.3 0.4 0.5	0.2~0.5		1.5~2.4	0.6~1.0	
5	1.2	6	1.00		3	10.00~40.00	0.5 0.6 0.7 0.8 0.9 ^{(*)2}	0.3~0.8		2.0~2.9	0.8~1.5	
6	1.5	10	1.25	PGKB (High hardness type)	2A	4	15.00~80.00 ^{(*)1}	0.6 0.7	2	2.5~3.9	1~45	0.8~1.5
8					5	0.8 0.9 1.0		3.5~4.9		1.0~2.0		
9					6	1.2 1.4 1.5 ^{(*)3}		4.0~5.9		1.5~3.0		
11	2.00	15	1.50	5A	8	15.00~80.00 ^{(*)1}	1.2 1.4 1.5 ^{(*)3} 1.6 ^{(*)4} 1.8 ^{(*)5}	3	4.5~7.9	1~60	2.0~4.0	
					1.2 1.4 1.5 ^{(*)3}		1.6 1.8 ^{(*)4} 2.0 ^{(*)5}					

(*)1 PGKB will be available for maximum L demension as 60.

(*)2 When P0.9(D3), G is 1.0.

(*)3 When P1.5(D5 • D6 • D8) • P1.6(D6), G is 1.2.

(*)4 When P1.8(D8), G is 1.1.

(*)5 When P1.8(D6) • P2.0(D8), G is 0.8.

Ⓜ For shape 4A, $R \geq \sqrt{(P/2)^2 + C^2}$

(*)4(*)5 P1.8 • P2.0 are not available for PGKB.



Part Number	L	P	A	C	V	S	R
PGEBA1A4	20.01	P0.8	A2	C0.5	V3.0		
PGEBA2A4	20.01	P0.8	A2				
PGEBA3A4	20.01	P0.8	A2	C0.5	S3.0		
PGEBA4A4	20.01	P0.8	A2	C0.5	R1.0		
PGEBA5A4	20.01	P0.8	A2	C0.5			



Quotation



Quotation

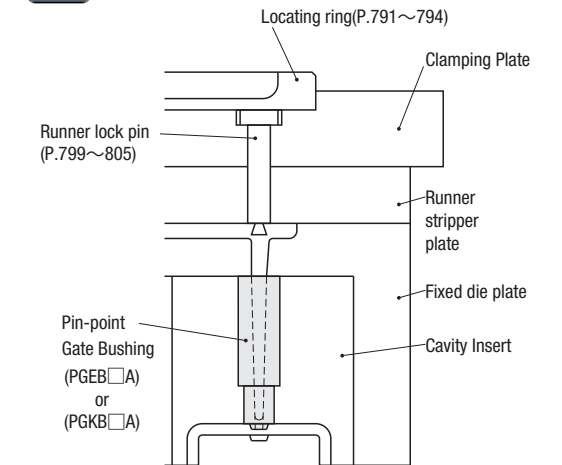

Part Number	L	P	A	C	V	S	R	(CC · LKC)
PGEBA1A4	20.01	P0.8	A2	C0.5	V3.0			CC

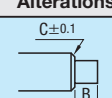
Alterations	Code	Spec.	1Code
	CC	C chamfering for inlay relief. D2 • 2.5 → C0.2 D3 • 4 → C0.3 D5~8 → C0.5	Quotation

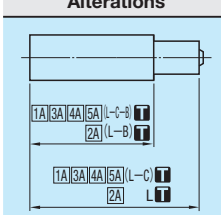
Alterations	Code	Spec.	1Code
	LKC	Changes the tolerances of the dimensions below. 1A (L-C-B) -0.05 ... 0 4A (L-C) +0.05 ... +0.02 2A (L-B) -0.05 ... -0.02 3A (L-C-B) 0 ... 0 5A (L-C) -0.05 ... 0	Quotation