

Schraubendruckfedern für super hohe Belastung

- ISWT -

viereckiger Drahtquerschnitt

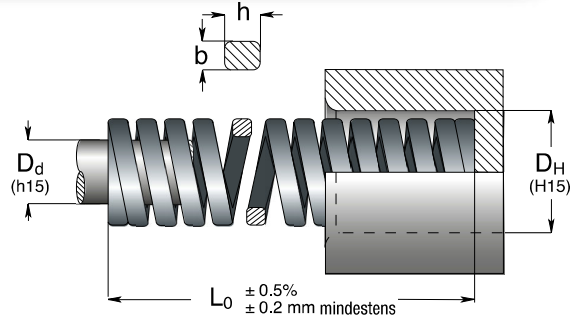

Katalog-Nr.	D_H		D_d	L_0	R	F max.	
	Bohrungs- durchmesser					Stangen- durchmesser	Feder- länge
	b x h			mm	$\pm 10\%$	mm	
	mm	mm	mm	N/mm			
ISWT10-20	10	5	20	580,0	2,2	1250	
ISWT10-30				360,0	3,5		
ISWT10-40				260,0	4,8		
ISWT10-50				200,0	6,0		
ISWT13-20	12,5	6,3	20	970,0	2,4	2000	
ISWT13-30				590,0	3,3		
ISWT13-40				400,0	5,0		
ISWT13-50				320,0	6,0		
ISWT16-20	16	8	20	1650,0	2,1	3500	
ISWT16-35				920,0	3,8		
ISWT16-50				580,0	6,0		
ISWT16-75				410,0	8,5		
ISWT16-100	3,4 x 6,9	100	280,0	12,5			
ISWT19-25	19	10	25	2270,0	2,2	5000	
ISWT19-40				1160,0	4,3		
ISWT19-50				830,0	6,0		
ISWT19-75				500,0	10,0		
ISWT19-100	4,1 x 8,3	100	380,0	14,0			
ISWT25-30	25	12,5	30	4550,0	2,2	10000	
ISWT25-50				2000,0	5,0		
ISWT25-60				1500,0	6,5		
ISWT25-75				1250,0	8,0		
ISWT25-100	900,0	11,1					
ISWT25-125	6 x 11	125	710,0	14,0			
ISWT32-35	32	16	35	5360,0	2,8	15000	
ISWT32-50				3000,0	5,0		
ISWT32-75				1670,0	9,0		
ISWT32-100				1200,0	12,5		
ISWT32-125	940,0	16,0					
ISWT32-150	7,4 x 13	150	810,0	18,5			
ISWT38-40	38	20	40	5710,0	3,5	20000	
ISWT38-50				4000,0	5,0		
ISWT38-75				2220,0	9,0		
ISWT38-100				1540,0	13,0		
ISWT38-150	1050,0	19,0					
ISWT38-200	8,25 x 16	200	740,0	27,0			
ISWT50-60	50	25	60	4605,0	7,6	35000	
ISWT50-75				3932,0	8,9		
ISWT50-100				2650,0	13,2		
ISWT50-125				2000,0	17,5		
ISWT50-150	1605,0	21,8					
ISWT50-200	11,8 x 17,8	200	1167,0	30,0			