

# Schraubendruckfedern für hyper starke Belastung - ISWW -

## viereckiger Drahtquerschnitt

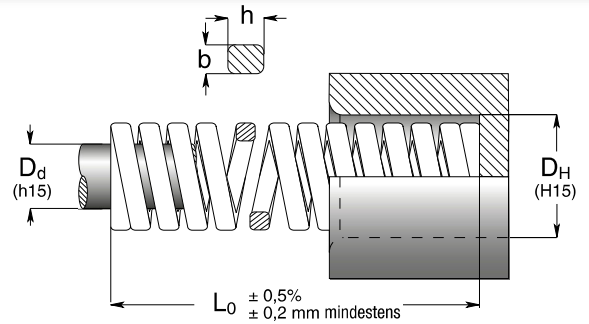

Katalog-Nr.	$D_H$	$D_d$	$L_0$	$R$	$F_{max.}$	
	Bohrungs- durchmesser	Stangen- durchmesser		Feder- länge		
	----- b x h		mm	$\pm 10\%$	N/mm	mm
ISWW16-20	16	6,3	20	1818,0	2,2	4000
ISWW16-35			35	1000,0	4,0	
ISWW16-50			50	615,0	6,5	
ISWW16-75			75	400,0	10,0	
ISWW16-100	4,6 x 5,0		100	286,0	14,0	
ISWW19-25	19	8	25	2400,0	2,5	6000
ISWW19-40			40	1333,0	4,5	
ISWW19-50			50	1000,0	6,0	
ISWW19-75			75	600,0	10,0	
ISWW19-100	5,1 x 6,5		100	429,0	14,0	
ISWW25-30	25	10	30	4800,0	2,5	12000
ISWW25-50			50	2400,0	5,0	
ISWW25-75			75	1500,0	8,0	
ISWW25-100			100	1000,0	12,0	
ISWW25-125	6,9 x 9,1		125	857,0	14,0	
ISWW32-35	32	12,5	35	6667,0	3,0	20000
ISWW32-50			50	3636,0	5,5	
ISWW32-75			75	2222,0	9,0	
ISWW32-100			100	1538,0	13,0	
ISWW32-125			125	1250,0	16,0	
ISWW32-150	9,25 x 10,8		150	1053,0	19,0	
ISWW38-40	38	16	40	7143,0	3,5	25000
ISWW38-50			50	5000,0	5,0	
ISWW38-75			75	2778,0	9,0	
ISWW38-100			100	1923,0	13,0	
ISWW38-150			150	1316,0	19,0	
ISWW38-200			10,5 x 12,6		200	